

# **ZANUSSI**

**REFRIGERATEUR  
CONGELATEUR  
FRIDGE-FREEZER  
ZD 19/4**

**NOTICE D'UTILISATION  
INSTRUCTION BOOKLET**

# WARNINGS

It is most important that this instruction book should be retained with the appliance for future reference. Should the appliance be sold or transferred to another owner, or should you move house and leave the appliance, always ensure that the book is supplied with the appliance in order that the new owner can be acquainted with the functioning of the appliance and the relevant warnings.

If this appliance featuring magnetic door seals is to replace an older appliance having a spring lock (latch) on the door or lid, be sure to make that spring lock unusable before you discard the old appliance. This will prevent it from becoming a death-trap for a child.

This must be done before the appliance is built into These warnings are provided in the interest of safety. You must read them carefully before installing or using the appliance.

## General Safety

- This appliance is designed to be operated by adults. Children should not be allowed to tamper with the controls or play with the product.
- It is dangerous to alter the specifications or modify this product in any way.
- Before any cleaning or maintenance work is carried out, be sure to switch off and unplug the appliance.
- This appliance is heavy. Care should be taken when moving it
- Ice lollies can cause frost burns if consumed straight from the appliance.

## Service/Repair

- Any electrical work required to install this appliance should be carried out by a qualified electrician or competent person
- This product should be serviced by an authorized Service Centre, and only genuine spare parts should be used.
- Under no circumstances should you attempt to repair the appliance yourself. Repairs carried out by inexperienced persons may cause injury or more serious malfunctioning. Refer to your local Service Centre, and always insist on genuine spare parts.
- This appliance contains hydrocarbons in its cooling unit; maintenance and recharging must therefore only be carried out by authorized technicians.

## Use

- The domestic refrigerators and freezers are designed to be used specifically for the storage of edible foodstuffs only.
- Best performance is obtained with ambient temperature between +18°C and +43°C (class T); +18°C and +38°C (class ST); +16°C and +32°C (class N); +10°C and +32°C (class SN). The class of your appliance is shown on its rating plate.

Warning: when the ambient temperature is not included within the range indicated for the class of this appliance, the following instructions must be observed: when the ambient temperature drops below the minimum level, the storage temperature in the freezer compartment cannot be guaranteed; therefore it is advisable to use the food stored as soon as possible.

- Frozen food must not be re-frozen once it has been thawed out.
- Manufacturers' storage recommendations should be strictly adhered to. Refer to relevant instructions.
- The inner lining of the appliance consists of channels through which the refrigerant passes. If these should be punctured this would damage the appliance beyond repair and cause food loss. DO NOT USE SHARP INSTRUMENTS to scrape off frost or ice. Frost may be removed by using the scraper provided. Under no circumstances should solid ice be forced off the liner. Solid ice should be allowed to thaw when defrosting the appliance. See defrost instructions.
- Do not place carbonated or fizzy drinks in the freezer as it creates pressure on the container, which may cause it to explode, resulting in damage to the appliance. Do not use a mechanical device or any artificial means to speed up the thawing process other than those recommended by the manufacturer. Never use metal objects for cleaning your appliance as it may get damaged.

## Installation

- During normal operation, the condenser and compressor at the back of the appliance heat up considerably. For safety reasons, minimum ventilation must be as shown in the relevant Figure.

**Attention: keep ventilation openings clear of obstruction.**

- Care must be taken to ensure that the appliance does not stand on the electrical supply cable. **Important:** if the supply cord is damaged, it must be replaced by a special cord or assembly available from the manufacturer or its service agent.
- There are working parts in this product which heat up. Always ensure that there is adequate ventilation as a failure to do this will result in component failure and possible food loss. See installation instructions.
- Parts which heat up should not be exposed. Wherever possible the back of the product should be against a wall.
- If the appliance has been transported horizontally, it is possible that the oil contained in the compressor flows in the refrigerant circuit. It is advisable to wait at least two hours before connecting the appliance to allow the oil to flow back in the compressor.

## Environment Protection

This appliance does not contain gasses which could damage the ozone layer, in either its refrigerant circuit or insulation materials. The appliance shall not be discarded together with the urban refuse and rubbish. Avoid damaging the cooling unit, especially at the rear near the heat exchanger. Information on your local disposal sites may be obtained from municipal authorities. The materials used on this appliance marked by the symbol  are recicable.

## CONTENTS

<b>Warnings</b>	26	Hints for storage of frozen food	30
<b>Use</b>	28	<b>Maintenance</b>	30
Cleaning the interior	28	Periodic cleaning	30
Operation	28	Periods of no operation	30
Temperature regulation	28	Interior light	30
Fresh food refrigeration	28	Defrosting	31
Freezing fresh food	28	<b>Customer service and spare parts</b>	32
Storage of frozen food	28	<b>Technical specifications</b>	32
Thawing	28	<b>Installation</b>	33
Ice-cube production	28	Electrical connection	33
Movable shelves	29	Location	33
Door shelves	29	Rear spacers	34
<b>Hints</b>	29	Door reversibility	34
hints for refrigeration	29		
Hints for freezing	29		

# USE

## Cleaning the interior

Before using the appliance for the first time, wash the interior and all internal accessories with luke-warm water and some neutral soap so as to remove the typical smell of a brand-new product, then dry thoroughly.



**Do not use detergents or abrasive powders, as these will damage the finish.**

## Operation

Insert the plug into the wall socket.

Open the refrigerator door and turn the thermostat knob, clockwise, beyond the «O» (STOP) position. The appliance will start to operate.

To stop operation, simply turn the thermostat knob to position «O»

## Temperature regulation

The temperature is automatically regulated and can be increased to achieve a higher temperature (warmer) by rotating the thermostat knob toward lower settings or reduced (colder) rotating the knob towards higher settings.

However, the exact setting should be chosen keeping in mind that the temperature inside the refrigerator depends on:

- room temperature;
- how often the door is opened;
- the quantity of food stored;
- location of appliance.

**A medium setting is generally the most suitable.**



**Important**

**If the ambient temperature is high or the appliance is fully loaded, and the appliance is set to the lowest temperatures, it may run continuously causing frost to form on the rear wall. In this case the dial must be set to a higher temperature to allow automatic defrosting and therefore reduced energy consumption.**

## Fresh food refrigeration

To obtain the best performance:

- do not store warm food or evaporating liquids in the refrigerator;
- do cover or wrap the food, particularly if it has a strong flavour.
- Position food so that air can circulate freely round it.

## Freezing fresh food

The 4-star compartment is suitable for long term storage of commercially frozen food and for freezing fresh food.

To freeze fresh foods it is not necessary to move the thermostat knob from the normal setting.

However, for a faster freezing operation, turn the thermostat knob to the coldest setting; but remember that, in this condition, the refrigerator compartment temperature might drop below 0°C. If this occurs reset thermostat knob to a warmer setting.

Place the food to be frozen on the shelf of the freezing compartment as this is the coldest part.

## Storage of frozen food

When first starting-up or after a period out of use, before putting the products in the compartment let the appliance run for at least two hours on the coldest setting, then turn the thermostat knob to the normal operating position.



**Important**

**In the event of accidental defrosting, for example due to a power failure, if the power has been off for longer than the value shown in the technical characteristics chart under “rising time”, the defrosted food must be consumed quickly or cooked immediately and then refrozen (after cooling).**

## Ice-cube production

This appliance is equipped with one or more trays for the production of ice-cubes. Fill these trays with water, then put them in the freezer compartment.

**Do not use metallic instruments to remove the trays from the freezer.**

## Thawing

Deep-frozen or frozen food, prior to being used, can be thawed in the refrigerator compartment or at room temperature, depending on the time available for this operation.

Small pieces may even be cooked still frozen, directly from the freezer: in this case, cooking will take longer.

## Movable shelves

The walls of the refrigerator are equipped with a series of runners so that the shelves can be positioned as desired.

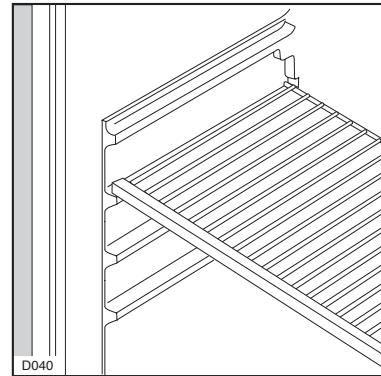

## Door shelves

To permit storage of food packages of various sizes, the door shelves can be adjusted in height. To make these adjustments proceed as follows: Gradually pull the shelf in the direction of the arrows until it comes off, then reposition as required.

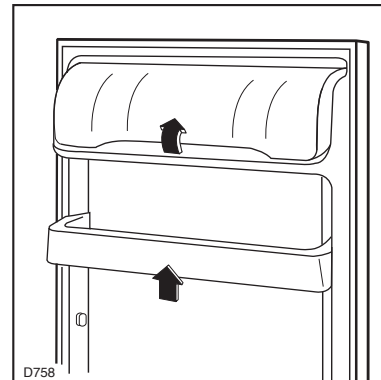

## HINTS

### Hints for refrigeration

Useful hints:

**Meat (all types):** wrap in polythene bags and place on the glass shelf above the vegetable drawer.

**For safety, store in this way only one or two days at the most.**

**Cooked foods, cold dishes, etc.:** these should be covered and may be placed on any shelf.

**Fruit and vegetables:** these should be thoroughly cleaned and placed in the special drawer(s) provided.

**Butter and cheese:** these should be placed in special airtight containers or wrapped in aluminium foil or polythene bags to exclude as much air as possible.

**Milk bottles:** these should have a cap and should be stored in the bottle rack on the door.

**Bananas, potatoes, onions and garlic, if not packed, must not be kept in the refrigerator.**

### Hints for freezing

To help you make the most of the freezing process, here are some important hints:

- the maximum quantity of food which can be frozen in 24 hrs. is shown on the rating plate;
- the freezing process takes 24 hours. No further food to be frozen should be added during this period;
- only freeze top quality, fresh and thoroughly cleaned, foodstuffs;
- prepare food in small portions to enable it to be rapidly and completely frozen and to make it possible subsequently to thaw only the quantity required;
- wrap up the food in aluminium foil or polythene and make sure that the packages are airtight;
- do not allow fresh, unfrozen food to touch food which is already frozen, thus avoiding a rise in temperature of the latter;
- lean foods store better and longer than fatty ones; salt reduces the storage life of food;
- water ices, if consumed immediately after removal from the freezer compartment, can possibly cause the skin to be freeze burnt;
- it is advisable to show the freezing-in date on each individual pack to enable you to keep tab of the storage time;

- on the inner door or special card (if supplied) you will find sketches of various animals and food types together with the recommended storage time (in months) from the time of freezing;
- **do not put carbonated liquids (fizzy drinks, etc.) in the freezer compartment as they may burst.**

## Hints for storage of frozen food

To obtain the best performance from this appliance, you should:

- make sure that the commercially frozen foodstuffs were adequately stored by the retailer;
- be sure that frozen foodstuffs are transferred from the foodstore to the freezer in the shortest possible time;
- not open the door frequently or leave it open longer than absolutely necessary.
- Once defrosted, food deteriorates rapidly and cannot be refrozen.
- Do not exceed the storage period indicated by the food manufacturer.

# MAINTENANCE



**Unplug the appliance before carrying out any maintenance operation.**

## Periodic cleaning

Clean the inside with warm water and bicarbonate of soda.

Rinse and dry thoroughly.

## Periods of non-operation

When the appliance is not in use for long periods, take the following precautions:

remove the plug from the wall socket;

remove all food;

defrost and clean the interior and all accessories;

leave the door ajar to allow air to circulate to prevent unpleasant smells.

## Interior light

The light bulb inside the refrigerator compartment can be reached as follows:

- unscrew the light cover securing screw.
- unhook the moving part as shown in the figure.

If the light does not come on when the door is open, check that it is screwed into place properly. If it still does not light up, change the bulb.

The rating is shown on the light bulb cover.

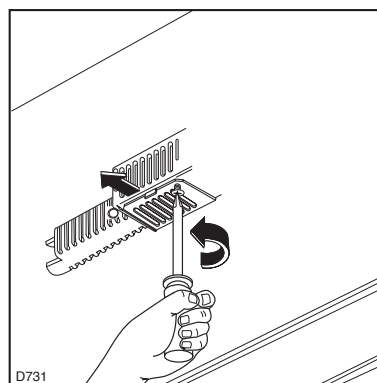

## Defrosting

Frost is automatically eliminated from the evaporator of the refrigerator compartment every time the motor compressor stops, during normal use. The defrost water drains out through a trough into a special container at the back of the appliance, over the motor compressor, where it evaporates.

**It is important to periodically clean the defrost water drain hole in the middle of the refrigerator compartment channel to prevent the water overflowing and dripping onto the food inside. Use the special cleaner provided, which you will find already inserted into the drain hole.**

The freezer compartment, however, will become progressively covered with frost. This should be removed with the special plastic scraper provided, whenever the thickness of the frost exceeds 4 mm. During this operation it is not necessary to switch off the power supply or to remove the foodstuffs.

**Never use sharp metal tools to scrape off frost from the evaporator as you could damage it.**

However, when the ice becomes very thick on the inner liner, complete defrosting should be carried out as follows:

1. pull out the plug from the wall socket or turn the thermostat knob to the «O» setting;
2. remove any stored food, wrap it in several layers of newspaper and put it in a cool place;
3. leave the door open, and introduce a container filled with hot water (taking care to place this on a layer of cardboard) so as to accelerate the defrosting process;
4. absorb all remaining water with a sponge and then accurately dry the freezer;
5. turn the thermostat knob back to the required setting or replace the plug in the power socket.
6. After two or three hours, reload the previously removed food into the compartment.



**Important:**

**Never use sharp metal tools to scrape off frost from the evaporator as you could damage it.**

**Do not use a mechanical device or any artificial means to speed up the thawing process other than those recommended by the manufacturer.**

**A temperature rise of the frozen food packs, during defrosting, may shorten their safe storage life.**

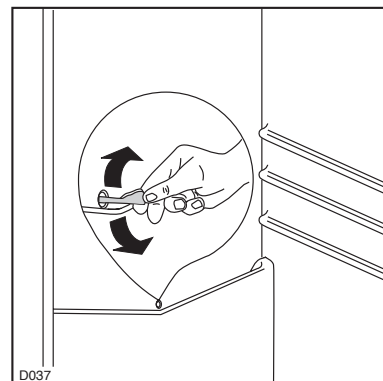

# CUSTOMER SERVICE AND SPARE PARTS

If the appliance is not functioning properly, check that:

- the plug is firmly in the wall socket and the mains power switch is on;
- there is an electricity supply (find out by plugging in another appliance);
- the thermostat knob is in the correct position.
- If there are water drops on the bottom of the cabinet, check that the defrost water drain opening is not obstructed (see “Defrosting” section).

- If your appliance is still not working properly after making the above checks, contact the nearest service centre.

To obtain fast service, it is essential that when you apply for it you specify the model and serial number of your appliance which can be found on the guarantee certificate or on the rating plate located inside the appliance, on the bottom left-hand side.

## TECHNICAL SPECIFICATIONS

Energy efficiency class	C
Net fridge capacity l	177
Net freezer capacity l	40
Energy consumption kWh/24h	1,20
Energy consumption kWh/year	438
Freezing capacity kg/24h	3
Rising time	17
Dimension (mm)	
Height	1415
Width	525
Depth	590
Width with open door at 90°	560
Depth with open door at 90°	1105

The technical info are shown on the rating plate situated on the left inside the appliance



# INSTALLATION

## Electrical connection

Before plugging in, ensure that the voltage and frequency shown on the serial number plate correspond to your domestic power supply. Voltage can vary by  $\pm 6\%$  of the rated voltage.

For operation with different voltages, a suitably sized auto-transformer must be used.

### The appliance must be earthed.

The power supply cable plug is provided with a contact for this purpose.

If the domestic power supply socket is not earthed, connect the appliance to a separate earth in compliance with current regulations, consulting a specialist technician.

### The Manufacturer declines all responsibility if the above safety precautions are not observed.

 This appliance complies with the following E.E.C. Directives:

- **87/308 EEC** of 2/6/87 relative to radio interference suppression.
- **73/23 EEC** of 19.2.73 (Low Voltage Directive) and subsequent modifications;
- **89/336 EEC** of 3.5.89 (Electromagnetic Compatibility Directive) and subsequent modifications.

## Location

The appliance should be installed well away from sources of heat such as radiators, boilers, direct sunlight etc.

For safety reasons, minimum ventilation must be as shown in Fig.

Appliance positioned under overhanging kitchen wall units (see A).

Appliance positioned without overhanging kitchen wall units (see B).

### Attention: keep ventilation openings clear of obstruction.

Two adjustable feet at the cabinet base allow accurate levelling of the appliance.

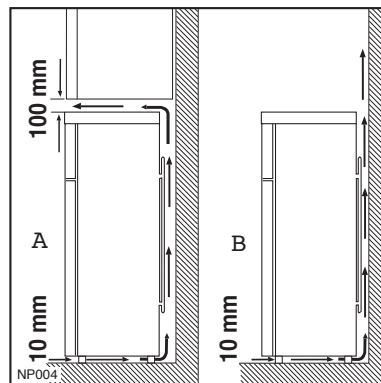

## Rear spacers

In the plastic envelope containing the Operating Instructions are also included two wall spacers to be fitted into the special openings provided on the back of the appliance. Push-fit the spacers into the openings, making sure that arrow (A) is positioned as per Fig. and then turn the spacers through 45° until they lock in (arrow (A) in a vertical position).

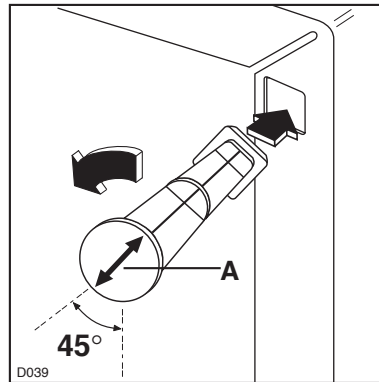

## Door reversibility

Before carrying out any work on the appliance, unplug it from the power socket.

1. Remove the upper hinge and slide the top door off the middle hinge.
2. Remove the middle hinge, turn it through 180° and refit it on the opposite side after having removed the plugs which mask the holes. The plugs must be refitted in the holes left open on the opposite side.
3. Refit the top door and the top hinge.
4. Unscrew the lefthand levelling foot, which will be refitted on the opposite side.
5. Unscrew the right-hand levelling foot, the corresponding hinge and refit all these on the left-hand side.
6. Reverse the handles after having removed the clip-in screw covers. The unused holes are masked with plastic plugs which should be removed and refitted in the holes left open.

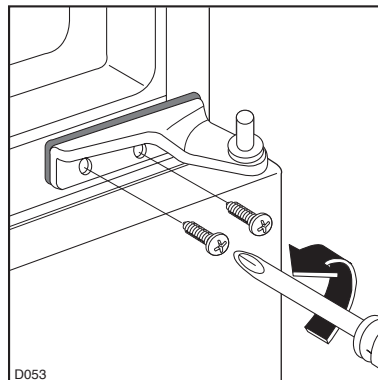
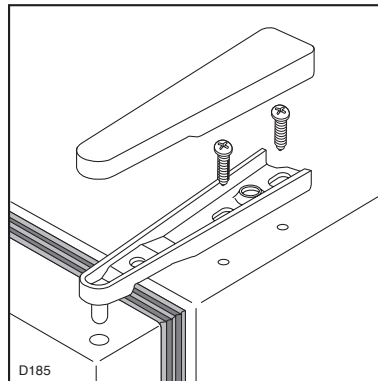

## Attention

After completion of the door reversibility operation, verify that the door gasket is adherent to the cabinet. If the ambient temperature is cold (i.e. in Winter), the gasket may not fit perfectly to the cabinet. In that case, wait for the natural fitting of the gasket or accelerate this process by heating up the part involved with a normal hairdrier.

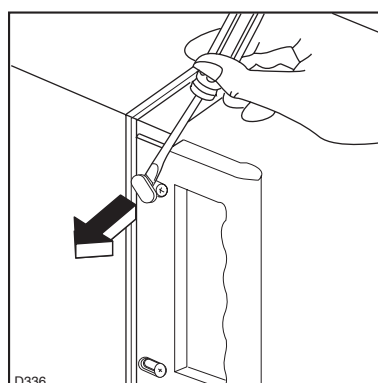
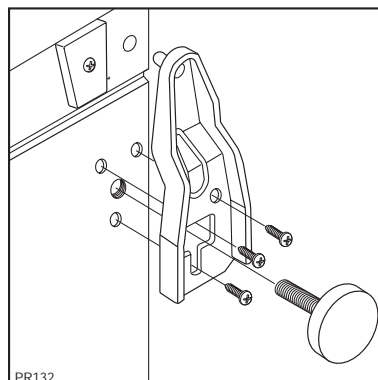

En cas de dysfonctionnement, le vendeur de votre appareil est le premier habilité à intervenir. A défaut (déménagement de votre part, fermeture du magasin où vous avez effectué l'achat...), **veuillez consulter** :

- **L'Assistance Technique Consommateurs**

pour toutes questions techniques.

ou

- **Le Service Conseil Consommateurs**

pour toutes questions ou informations concernant l'utilisation de votre appareil ou pour toutes autres questions commerciales.

Vous trouverez ci-dessous les coordonnées de ces deux services.

En cas d'intervention sur votre appareil,  
exigez du Service Après-Vente  
les Pièces de Rechange certifiées Constructeur.



En appelant un Service Après-Vente,  
indiquez-lui toutes les références et numéros ( PNC, N° de série, ... ).  
Ces indications figurent sur la plaque signalétique.

**Questions Techniques**  
**Assistance Technique Consommateurs**  
**ZANUSSI**

**B.P. 20139 - 60307 SENLIS Cedex**

**Tél : 03 44 62 27 78**

**e-mail : zanussi.frs@notes.electrolux.fr**

permanence tél. du lundi au vendredi de 8 h 30 à 12 h 30 et de 13 h 30 à 18 h 00

**Choisir un nouvel appareil et/ou conseils d'utilisation**  
**Service Conseil Consommateurs**  
**ZANUSSI**

**B.P. 50142 - 60307 SENLIS Cedex**

**Tél : 03 44 62 29 99 - Fax : 03 44 62 21 54**

**e-mail : zanussi-scc.fau@notes.electrolux.fr**

permanence téléphonique du lundi au vendredi de 8 h 30 à 18 h 00

